

# Well Buddy 1000P

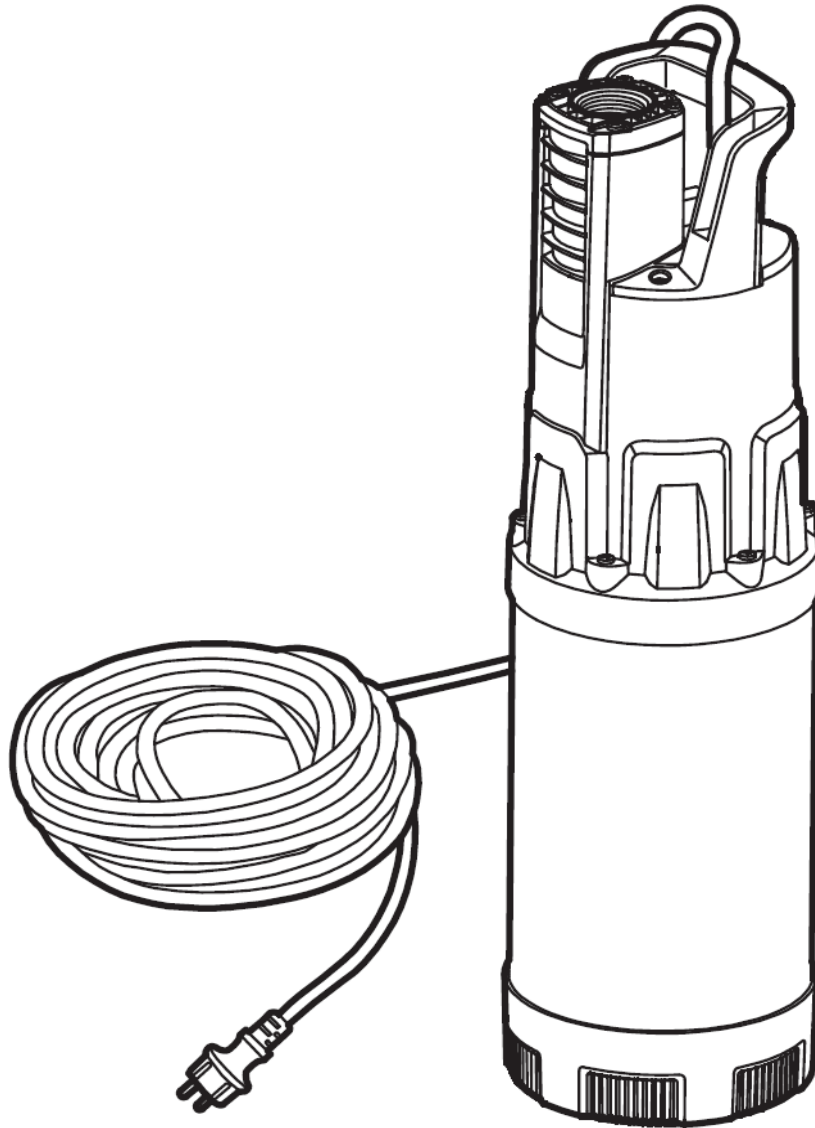

Before Installing And Use Please Read The Instruction Manual Carefully



# Well Buddy 1000P

SECTION	DESCRIPTION
1	SAFETY INSTRUCTIONS
2	APPLICATION
3	INSTALLATION
4	ELECTRICAL CONNECTION
5	OPERATION
6	MAINTENANCE
7	TROUBLE SHOOTING
8	DISASSEMBLY AND DISPOSAL
9	DIMENSIONAL DRAWING
10	WARRANTY

## SECTION 1 SAFETY INSTRUCTIONS

This instruction manual contains essential information that must be observed during installation, operation and servicing. It is therefore important that the installer and the responsible technician/operator read this instruction manual before the equipment is installed and put into operation. The manual must always be available at the location where the pump or the plant is installed. Failure to observe the safety instructions can lead to the loss of all warranty.

In this instruction manual, safety information is distinctly labelled with particular symbols. Disregarding this Information can be dangerous.



### ATTENTION

General danger to people



### DANGER - ELECTRIC SHOCK RISK

Warning of electrical voltage

### QUALIFICATION AND TRAINING OF PERSONNEL

All personnel involved with the operation, servicing, inspection and installation of the equipment must be suitably qualified for this work and must have studied the instruction manual in depth to ensure that they are sufficiently conversant with its contents. The supervision, competence and areas of responsibility of the personnel must be precisely regulated by the operator. If the personnel do not have the necessary skills, they must be instructed and trained accordingly.

### SAFETY CONSCIOUS WORKING

The safety instructions in this instruction manual, the existing national regulations regarding accident prevention, and any internal working, operating and safety regulations must be followed

### SAFETY INSTRUCTIONS FOR THE USER

All legal regulations, local directives and safety regulations must be followed. Legal regulations must be observed

## **SAFETY INSTRUCTIONS FOR INSTALLATION, INSPECTION AND MAINTENANCE WORKS**

As a basic principle, works may only be carried out to the equipment when it is shut down. Pumps or plant that convey harmful substances must be decontaminated. All safety and protection components must be re-fitted and/or made operational immediately after the works have been completed. Their effectiveness must be checked before restarting, taking into account the current regulations and stipulations.

### **UNAUTHORISED MODIFICATIONS, MANUFACTURE OF SPARE PARTS**

The equipment may only be modified or altered in agreement with the manufacturer. The use of original spare parts and accessories approved by the manufacturer is important for safety reasons. The use of other parts can result in liability for consequential damage being rescinded. All materials in contact with water have been tested and approved, therefore only original replacement parts should be used.

### **UNAUTHORISED OPERATING METHODS**

The operational safety of the supplied equipment is only guaranteed if the equipment is used for its intended purpose. The limiting values given in the "Technical Data" section may not be exceeded under any circumstances

### **INSTRUCTIONS REGARDING ACCIDENT PREVENTION**

Never work alone. Always wear a hard hat, safety glasses and safety shoes and, if necessary, a suitable safety belt. Before carrying out welding works or using electrical devices, check to ensure there is no danger of explosion.

For the sake of your health, be sure to pay meticulous attention to cleanliness wherever you are working. Make sure that there are no toxic gases in the working area

Observe the relevant occupational health and safety regulations and keep first aid materials available.

In some cases, the pump and the pumping medium may be hot and could cause burns. For installations in areas subject to explosion hazards, special regulations apply!



### **DANGER - ELECTRIC SHOCK RISK**

The pump must only be connected to sockets that have been installed properly in accordance with the regulations and are protected with safety switch (RCD,30mA)

Only qualified electricians may carry out electrical works to the pump or the controls

Always pull out the mains plug before carrying out any work on the pump

Check the rubber hose for mechanical or chemical damage. A damaged or kinked hose must be replaced.

## SECTION 2 APPLICATION

The Well Buddy 1000P is suitable for pumping clean water with no suspended solids or abrasive material. Manufactured with anti corrosive and rust proof materials. Supplied with 15 metre power cable. Automatic pressure control



### **DANGER**

Never use the pump for flammable and/or explosive liquids

Improper use of the pump can lead to physical injury and/or material damage. Improper use of the product will render the warranty null and void

### **SOUND PRESSURE LEVEL**

The sound pressure level is below 70dB (LpA) on all models

### **TRANSPORT AND STORAGE**

On delivery, check that the electric pump has not been subject to damage during transport; in this case notify the retailer immediately. Check procedure phases - check the exterior of the packaging - remove all product packaging material - inspect the product for possible damaged parts - contact the retailer if any defects are found.

Use the original packaging to return the product to the retailer in the event of defects; otherwise dispose of all packaging materials according to current local standards

If after use the pump will be stored away for a long period, wash the pump body out with clean water.



### **DANGER**

Handle the product in observance of current accident prevention standards. Never lift the pump by the power cable or float switch

During storage, protect the product from humidity, dust, heat sources, mechanical damage and external contaminants in order to conserve the quality of the water subsequently placed in contact with the pump

### SECTION 3 INSTALLATION



When installing, please ensure the pump is disconnected from the power supply.

Please use pump handle to move or lift the pump

The Well Buddy 1000P is fitted with a non return valve, this will avoid the water circulating when the pump is switched off. It is advisable to install a quick release connection on the delivery pipe for disconnecting the pump for cleaning and maintenance

Connect pipework making sure all joint are sealed correctly. Any connection leaks will cause the pump to operate frequently and reduce the working life

Use a rope and fasten it to the pump handle to lower and immerse the pump

Maximum submersion depth 12 metres.

Maximum liquid temperature 35°C

Lowest pump starting level 60mm

Lowest pump sucking level 50mm

15 Metre Power Cable



#### **ATTENTION**

To avoid breakdown of the system with the risk of physical injury, use pipelines, connectors and accessories suited to the maximum operating pressure values

All pipeline connections must be made by qualified personnel in conformity with current local standards.

## SECTION 4 ELECTRICAL CONNECTION



### DANGER - ELECTRIC SHOCK RISK

Ensure that the rated voltage and frequency correspond to those of the specifications of the mains power available.

The electrical connection must be made according to current local standards.

Before any intervention on the pump, disconnect the electrical mains. Ensure that the electrical power supply cannot be restored inadvertently.

The electrical cables must be protected, in particular from high temperatures, vibrations and impact, which could cause mechanical or chemical damage.

The electrical power line must be fitted with a short circuit protection device, and a residual current device RCD with high sensitivity (30mA)

The electric power line must be fitted with an external main switch with a contact opening gap compliant with current local standards.

The single phase motors are protected against temperature and current overload by means of thermal cutout devices in the winding. The motor protection is reset automatically on elapse of the time required for the electric motor to cool down.

### ELECTRICAL CONNECTIONS

230v model is supplied with a 15m power cable and plug. Grounding is done when plugged into a power outlet

Model	Voltage	Outlet	LM/HM	Kw	Amp	H x W x L mm	Kg	Code
Well Buddy 1000P	230v	1" BSP	100/45	1	4.9	438 x 151 x 151	13	022-952

## SECTION 5 OPERATION



### ATTENTION

Before starting the pump, make sure all connections are correct

Use the electric pump according to the performance specifications as stated on the data plate. Before using the pump, read application chapter for a proper use

Start the pump by inserting the plug into an appropriate outlet

Test the pump for operation. Close the valve/tap (example a trigger gun on the end of a hose) Check the pump turns off. Open the valve/tap (example release the trigger gun) Check the pump turns on

## SECTION 6 MAINTENANCE



### DANGER - ELECTRIC SHOCK RISK

Before any intervention on the pump, disconnect the electrical mains. Ensure that the electrical power supply cannot be restored inadvertently



### ATTENTION

Refer to safety instructions

In normal conditions, the electric pumps do not require any scheduled maintenance. With a view to prevention of possible faults, it is recommended to periodically check the pressure delivered and current absorption. A reduction in pressure is symptomatic of pump wear. An increase in current absorption is symptomatic of abnormal mechanical friction in the pump

### Cleaning The Filter

It may be required to clean the pump using a steel brush to scrap of any debris accumulated on the outer surface, paying special attention to the filter area. Rinse off with clean water

Special maintenance may be required to clean the pump if it not used for prolonged periods (e.g. for an entire season) it should be drained completely rinsed with clean water and stored in a dry location

## SECTION 7 TROUBLESHOOTING GUIDE



### **ATTENTION**

Refer to safety instructions

### **THE PUMP DOES NOT WORK**

No power - check that no electrical connections are loose or defective

Check the mains voltage (230v)

Fuse blown - check that the cables and relative connections are not defective and replace the fuse if necessary

The 230v single phase motor thermal cutout has tripped this is reset automatically once the motor has cooled

Motor overload cutout has tripped - check that the cables and relative connections are not defective, check that the pump is not blocked mechanically, or whether the pump motor winding is damaged

### **THE PUMP STOPS AFTER A SHORT INTERVAL OF OPERATION DUE TO A TRIPPED MOTOR PROTECTION DEVICE**

Excessive current absorption check the operating condition of the pump

If foreign bodies are present, blocking hydraulics = clean the hydraulic components

The 230v single phase motor thermal cutout has tripped = this is reset automatically once the motor has cooled; check installation conditions

Thermal cutout protection setting or fuses not suitable = check protection devices with respect to rated current of pump

Power cable damaged = replace component

### **THE PUMP STARTS UP BUT DOES NOT DELIVER LIQUID**

The pump takes in air, check the liquid level, check connections are air tight

### **PUMP PERFORMANCE IS REDUCED**

Pipelines obstructed check pipelines, check valves

Delivery pipe is partially obstructed with impurities, clean suction pipe

Delivery pipe is leaking, repair or replace

If the problem has not been eliminated after carrying out the above operations contact the supplier or service centre



## SECTION 8 DISASSEMBLY AND DISPOSAL



### **DANGER - ELECTRIC SHOCK RISK**

Before any intervention on the pump, disconnect the electrical mains. Ensure that the electrical power supply cannot be restored inadvertently

Disconnect the pump electrically from the system according to safety standards

Open the tap nearest to the pump to decrease the system's pressure

This product or any part of the latter must be disposed of in accordance with local standards using the public or private waste collection authorities as required

## SECTION 9

### **DIMENSIONAL DRAWING**

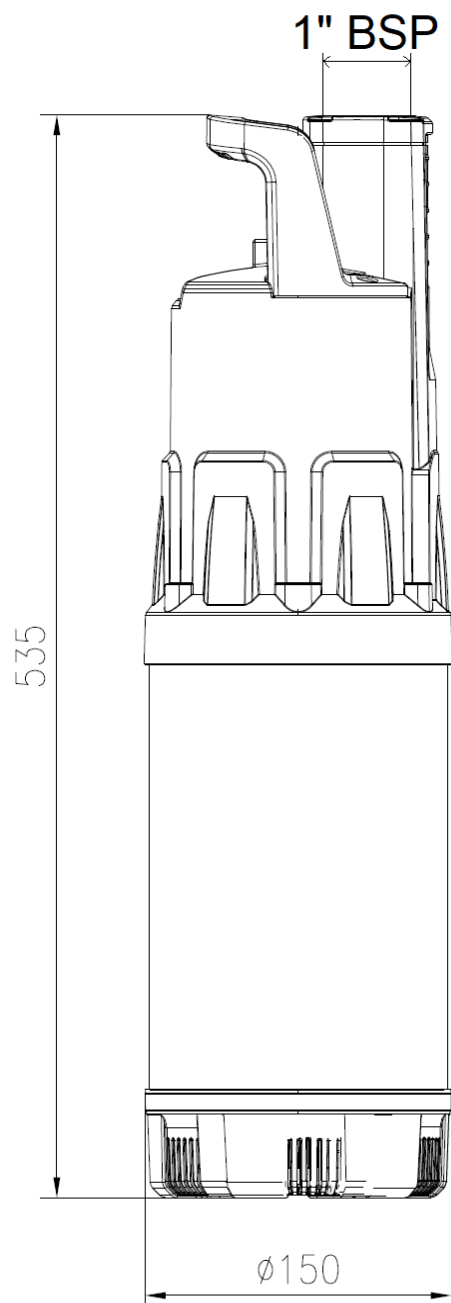

## SECTION 10

## WARRANTY

### Conditions of Warranty Terms

Products are covered by Warranty relating to manufacturing defect or failing and/or those of the material used. The components subject to fair wear and tear, such as bearings, seal housing bushes, seals and o rings are not covered under the manufactures warranty.

The Warranty right starts from the date of sale and must be certified by the sale's receipt and is covered for 12 months (1 Year) from sale against fault of manufacture.

The warranty is not accepted in case of:

Failures due to wrong treatment or operation.

Failures due to wrong implementation or storage.

Failure due to wrong hydraulic or electrical connections or installations.

Failures due to by a lack of an adequate protection.

Failures to reasons of force of nature or other uncontrollable factors.

Failures due to abrasive, or corrosive liquids or different from those allowed.

The use of the item beyond the limits indicated on the plate or in wrong conditions.

Failures due to lack of maintenance.

Failures due to incorrect user's actions.

Failure due to wear and tear in certain applications.

In case of pumps the warranty is void if they have not been installed with accurate motor over load protection.

The Warranty consists of repair or replacement by the service centre or supplier at their discretion for the defective pump or parts.

The Warranty is a return to base warranty. Faulty or defective pumps will need to be inspected at the service centre or supplier before repair or replacement is issued. Pumps found to be not covered under warranty will be assessed and quoted for repair.



ONLY FOR EU COUNTRIES Do not dispose of electric tools together with household waste material! In observance of European Directive 2002/96/EC on waste electrical and electronic equipment and its implementation in accordance with national law, electric tools that have reached the end of their life must be collected separately and returned to an environmentally compatible recycling facility